

GCAN-600

Vehicle OBD interface intelligent analysis module

User Manual



Document version: V1.28 (2017/10/24)

Contents

1 Introduction.....	3
1.1 Overview.....	3
2 Technical parameters.....	4
2.1 Supporting protocol.....	4
2.2 Technical specifications.....	4
2.3 Pin definition and function.....	5
2.4 Package information.....	6
2.5 Typical pad design (unit: mm)	6
2.6 Typical application circuit diagram.....	7
2.7 Working model.....	9
2.8 External reset input.....	9
3 AT instructions.....	10
3.1 AT instructions.....	10
3.2 ATI instructions.....	10
3.3 ATRTON open vehicle real-time data flow.....	11
3.4 ATUTON opens a user specific data flow.....	11
3.5 ATPID to obtain custom PID data.....	12
3.6 ATDTC read the fault code.....	14
3.7 ATCDI clear ECU fault code.....	14
3.8 ATADJ total mileage correction.....	14
3.9 ATVIN read VIN code.....	14
Sales and service.....	15

1 Introduction

1.1 Overview

GCAN-600 is an automobile CAN bus decoding module, it applies to all kinds of automobiles which's ECU use ISO15765 protocol to communicate.

GCAN-600 module can receive all the CAN bus data which sent by sensors in automobile, then parse and resend it to UART serial bus. So users don't need to know much about the CAN bus protocols in automobile, just integrated GCAN-600 into their own system(SCM, PC serial bus, GPS, DVD, PND and so on), then the system can connect to automobile's CAN bus to read the sensors' data such as speed, engine speed, coolant temperature, battery voltage and so on.

1.2.1 Hardware

- Module can receive data through OBD port
- Support almost all the automobile that use ISO15765 protocol
- All the sensors' data decoding by the module itself
- UART serial bus send data with ASCII
- Mileage, fuel consumption, DTC can be read
- Driving habits can be computed
- Two kinds of working mode.(introduced in chapter 3)
- Support on-demand customization
- Working temperature range from -40 to 85 °C
- Size: (L)18 mm * (W)12 mm * (H)4 mm

2 Technical parameters

2.1 Supporting protocol

Serial number	Protocol	Standard
1	CANBUS_11B_500K	ISO15765
2	CANBUS_29B_500K	
3	CANBUS_11B_250K	
4	CANBUS_29B_250K	

2.2 Technical specifications

Connection mode	
10Pin	10Pin,holes with 2.0mm spacing
Interface characteristics	
UART baud rate	57600bps
UART level	Standard TTL level
CAN interface	Follow ISO 11898, CAN2.0A/B
CAN baud rate	250Kbit/s, 500Kbit/s
Power	
Voltage	+3.3V DC
Current	Max 70mA
Environmental testing	
Temperature	-40℃~+85℃
Humidity	15%~90%RH, No condensation
EMC test	EN 55024:2011-09 EN 55022:2011-12
Ingress protection	IP 20
Basic Information	
Outline size	12mm *18mm *4mm
Weight	10g

2.3 Pin definition and function

PIN Name	PIN #	Pad type	Description	Note
3.3V	1	3.3V	3.3V	
RS232 TX	2	TTL	UART TXD	
RS232 RX	3	TTL	UART RXD	
CAN TX	4	TTL	CAN TX	
CAN RX	5	TTL	CAN RX	
NC	6			
NC	7			
RST	8	3.3V	0V Reset	
IAP	9	0V	3.3V Upgrade kernel 0V Run mode	
GND	10	0V		

2.4 Package information

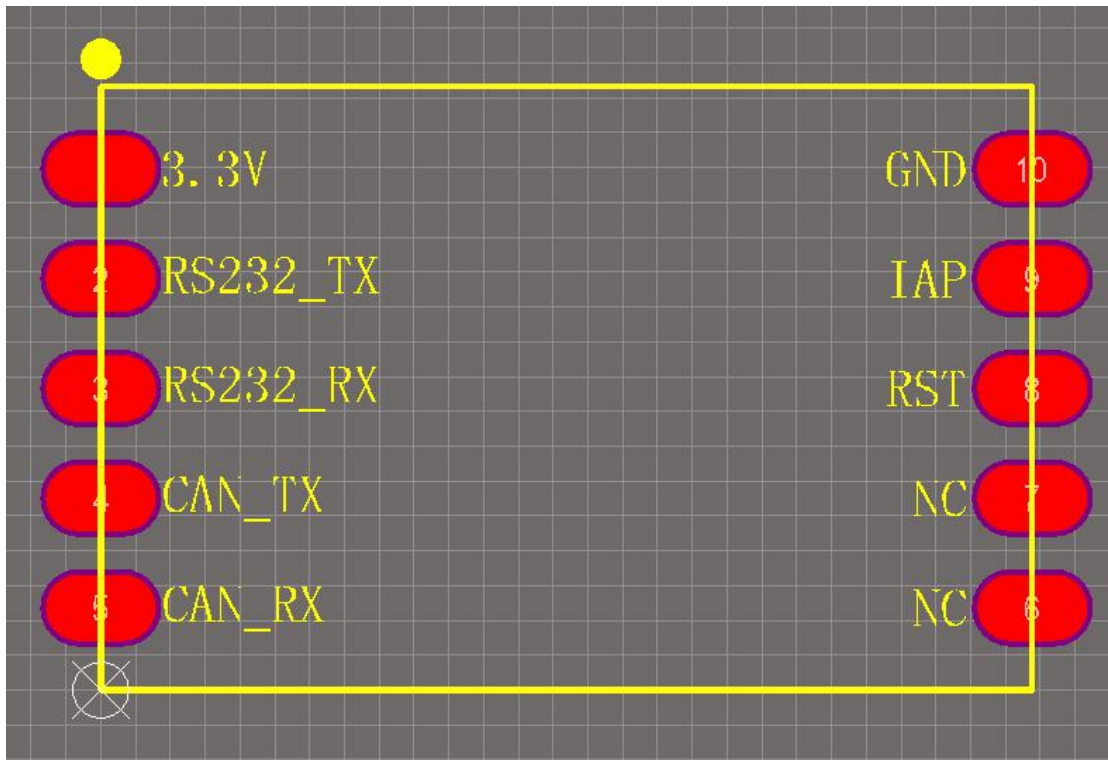

2.5 Typical pad design (unit: mm)

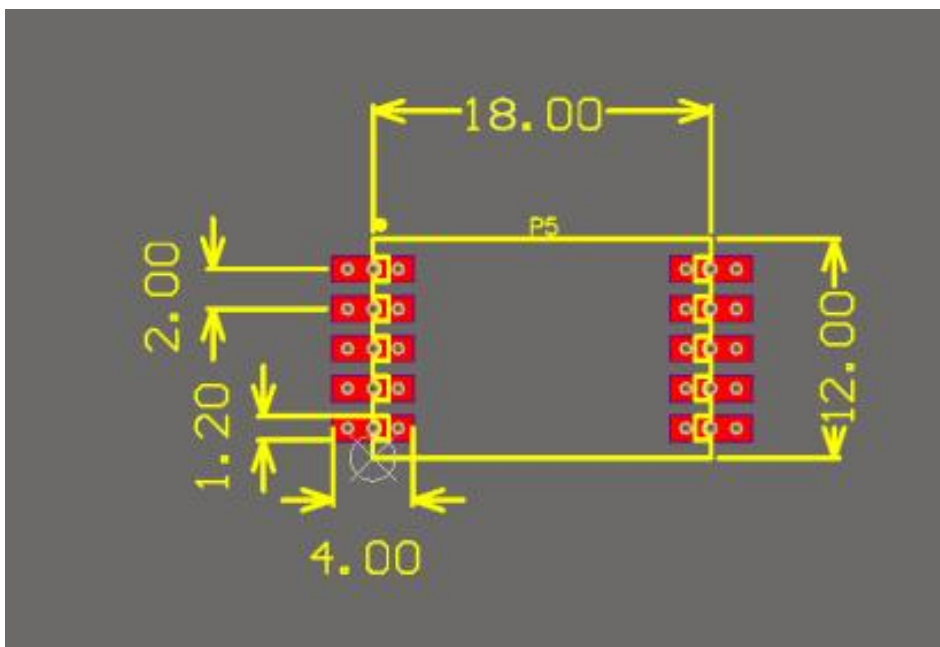

2.6 Typical application circuit diagram

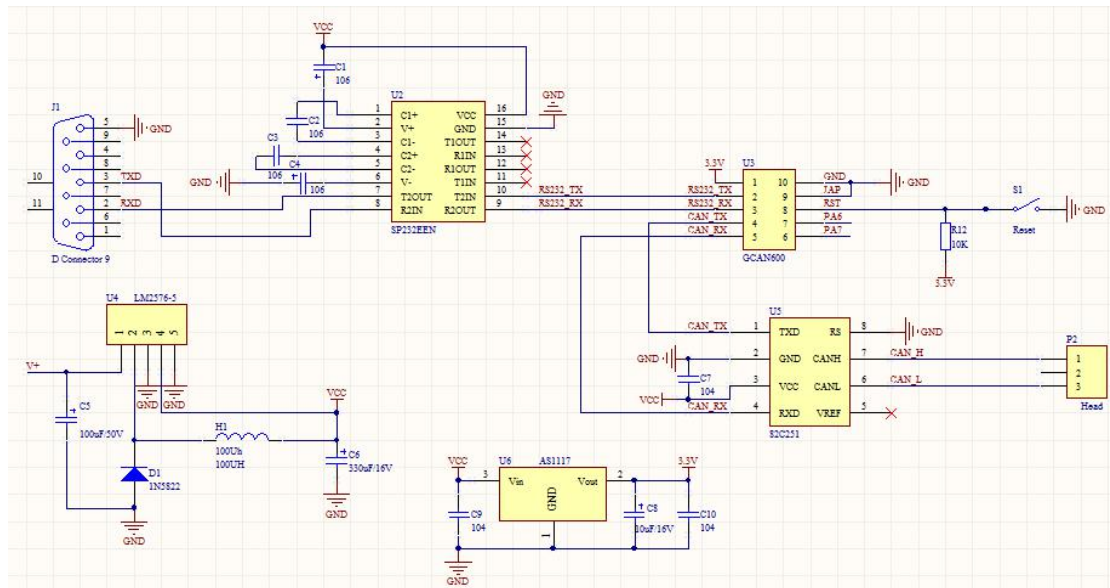

2.6.1 Power supply module

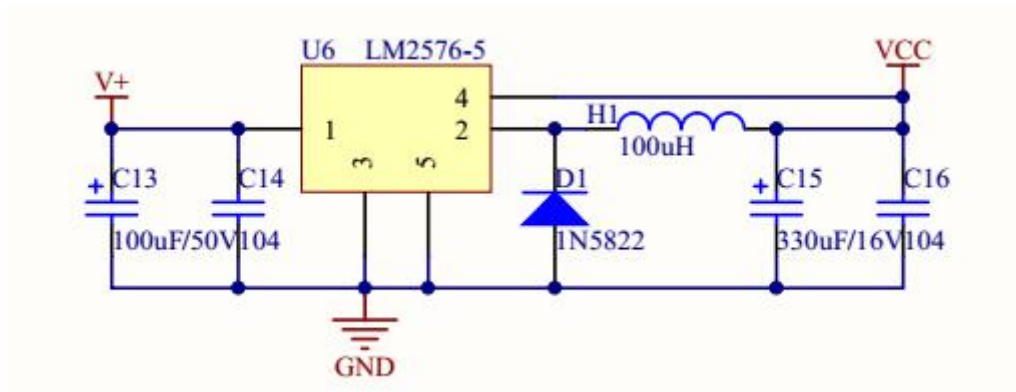

LM2576 :Power supply module, rated voltage is 9-30V

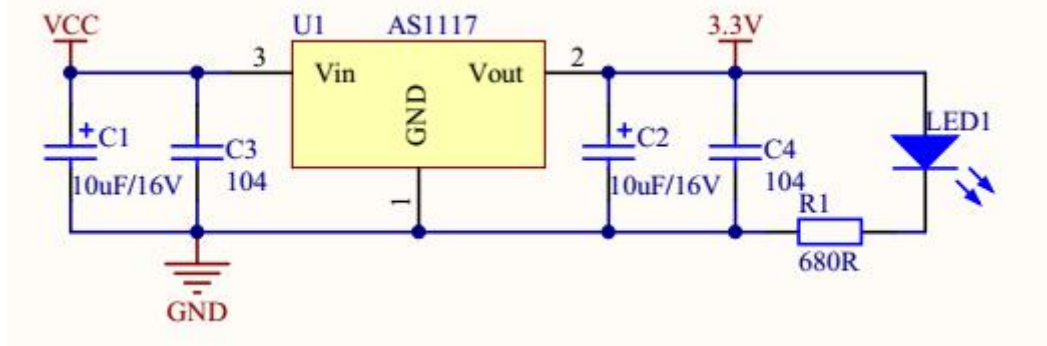

AS1117: Voltage Converter, turn 5V into 3.3V for power supply on chip.

2.6.2 Serial communication

The serial communication mainly adopts SP232EEN as RS232 transceiver.

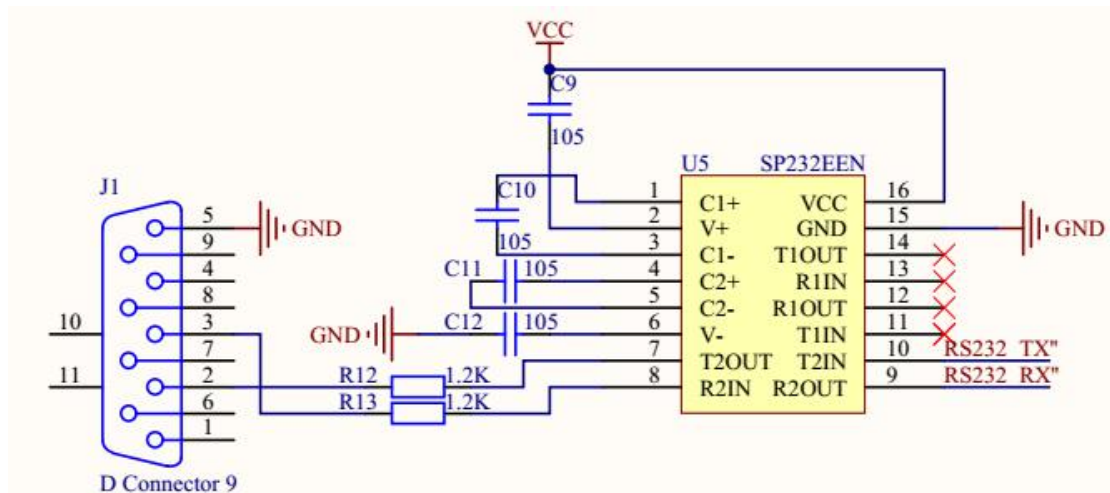

TX of RS232 in the chip (RS232 TX) is connected to TX of the GCAN600 module. RX of RS232 in the development board (RS232 RX) is connected to RX of the GCAN600 module. And the VCC is 5V power supply.

2.6.3 CAN communication

CAN communication mainly uses high speed CAN transceiver: PCA82C251, TJA1040, TJA1050 and so on.

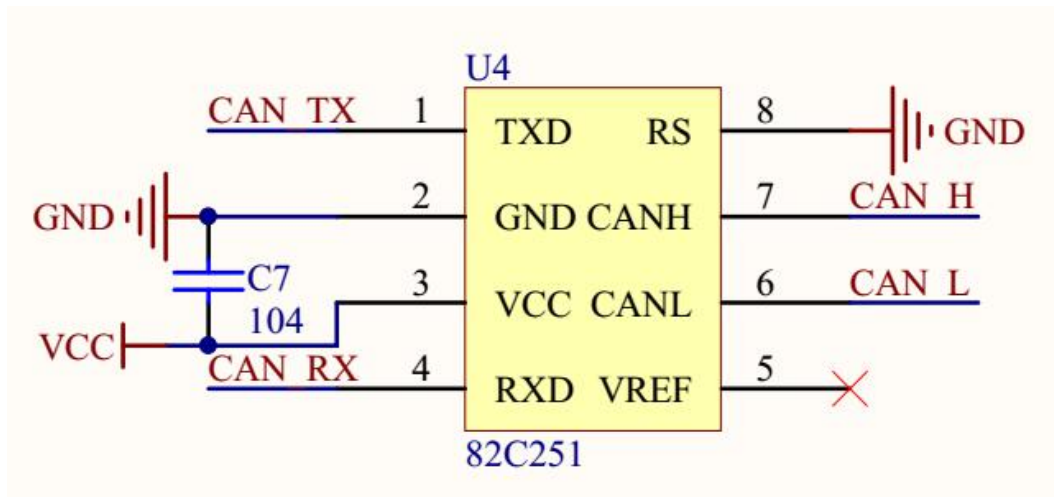

CAN TX and CAN RX are connected to TX and RX of GCAN600 module respectively.

2.7 Working model

Mode	Function
Normal	Common mode, connecting to CAN bus automatically, transmitting data via UART every one second
Normal work	ASK-ACK Q & A mode
USER DEFINE	User defined mode
Upgrade kernel	Upgrade the kernel via UART

2.8 External reset input

The device enters the reset state by external reset pin RST.

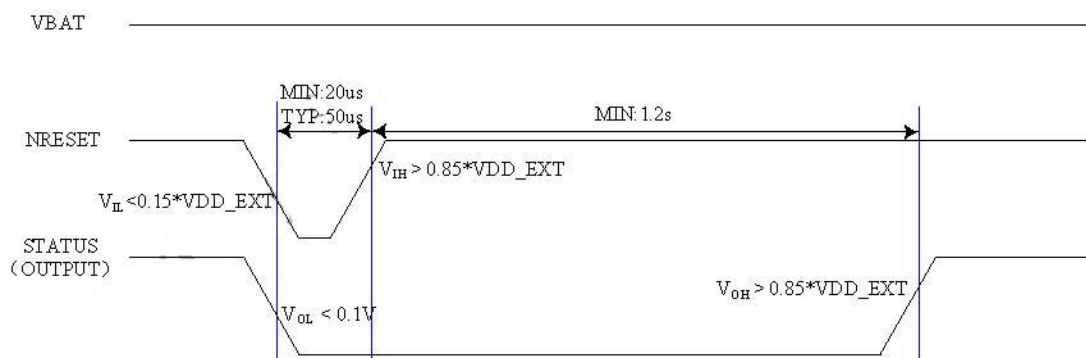

3 AT instructions

AT	Test connection instruction
ATI	Device information data returned
ATRTON	Open the real-time data flow of vehicle
ATRTOFF	Close the real-time data flow of vehicle
ATUTON	Open the specific data flow of user
ATUTOFF	Close the specific data flow of user
ATPID	Get the custom PID data
ATDTC	Read fault code
ATCDI	Remove the ECU fault code
ATADJ	Total mileage correction
ATVIN	Read the VIN code

3.1 AT instructions

Test module connection status.

Example:

Send instruction

> AT

Reception

> OK

3.2 ATI instructions

Data number	Data first	Note
(ATI)	\$GCAN=	
1	ECU Communication protocol	
2	Module serial number	
3	Hardware version number	
4	Firmware version number	

Example:

Send instruction

>ATI

Reception

>\$GCAN=CANBUS_11B_500K,GC000000000,312502,V100

3.3 ATRTON open vehicle real-time data flow

Data number	Data header	Note
(ATRTON)	\$OBDRT=	
1	Battery voltage (v)	ATPID=066
2	Engine RPM (rpm)	ATPID=012
3	Vehicle speed (km/h)	ATPID=013
4	Throttle Angle (%)	ATPID=017
5	Engine load (%)	ATPID=04
6	Coolant temperature (°C)	ATPID=05
7	Instantaneous fuel consumption (L/h or L/100km)	ATPID=016
8	Average fuel consumption (L/100km)	ATPID=016
9	The remaining oil in the fuel tank (%)	ATPID=047
10	The number of current fault codes	ATPID=01
11	Time since engine start	ATPID=031
12	Intake air temperature	ATPID=015

Example:

Send instructions

> ATRTON (set the instructions, the module interval 1s cycle sent, using ATRTOFF to close)

Reception

>\$OBDRT=14.01500,20,17.00,50.00,80,8.00,8.00,65.00,0

3.4 ATUTON opens a user specific data flow

Open user specific data flow.

Note: this data flow is customized for a part of users. If the GCAN-600 module that

you bought is not specially customized, the module does not have this data flow.

Data number	Data header	Note
(ATUTON)	\$USERT=	
1	Average speed (km/h)	
2	Mileage (km)	
3	Average fuel consumption (L/100km)	
4	Brake signal (0/1)	
5	Boot state (0/1)	
6	Lock signal (0/1)	
7	Steering wheel angle (degree)	
8	Seat belt status (0/1)	
9	Car light signal (0/1)	
10	Hand brake signal (0/1)	
11	Tail box signal (0/1)	

Example:

Send instructions

> ATUTON (set the instructions, the module interval 1s cycle sent, using ATUTOFF to close)

Reception

>\$USERT =57.01540,8.00,0, 1, 1.....

3.5 ATPID to obtain custom PID data

PID	Data header	Min	Max	unit
01	Monitor status sinceDTCs cleared. (Includes malfunction indicator lamp (MIL) status and number of DTCs.)	0	127	PCS
04	Calculated engine load value	0	100	%
05	Engine coolant temperature	-40	215	°C
06	Short term fuel % trim—Bank 1	-100	99.22	%
07	Long term fuel % trim—Bank 1	-100	99.22	%
08	Short term fuel % trim—Bank 2	-100	99.22	%
09	Long term fuel % trim—Bank 2	-100	99.22	%
010	Fuel pressure	0	765	kPa
011	Intake manifold pressure	0	255	kPa
012	Engine RPM	0	9999	rpm

013	Vehicle speed	0	255	km/h
014	Timing advance	-64	63.5	°
015	Intake air temperature	-40	215	°C
016	MAF air flow rate	0	655.35	g/s
017	Throttle position	0	100	%
031	Run time since engine start	0	65535	s
033	Distance traveled with malfunction indicator lamp (MIL) on	0	65535	km
034	Fuel Rail Pressure (relative to manifold vacuum)	0	5177.265	kPa
035	Fuel Rail Pressure (diesel)	0	655350	kPa
044	EGR	0	100	%
045	EGR Error	-100	99.22	%
046	Evaporative purge instructions	0	100	%
047	Fuel Level Input	0	100	%
048	Number of warm-ups since codes cleared	0	255	N/A
049	Distance traveled since codes cleared	0	65535	km
050	Evap. System Vapor Pressure	-8192	8192	Pa
051	Barometric pressure	0	255	kPa
060	Catalyst Temperature Bank 1, Sensor 1	-40	6513.5	°C
061	Catalyst Temperature Bank 2, Sensor 1	-40	6513.5	°C
062	Catalyst Temperature Bank 1, Sensor 2	-40	6513.5	°C
063	Catalyst Temperature Bank 2, Sensor 2	-40	6513.5	°C
066	Control module voltage	0	65.535	V
067	Absolute load value	0	25700	%
068	instructions equivalence ratio	0	2	N/A
069	Relative throttle position	0	100	%
070	Ambient air temperature	-40	215	°C
071	Absolute throttle position B	0	100	%
072	Absolute throttle position C	0	100	%
073	Accelerator pedal position D	0	100	%
074	Accelerator pedal position E	0	100	%
075	Accelerator pedal position F	0	100	%
076	Throttle actuator instructions	0	100	%

077	Time run with MIL on	0	65535	min
078	Time since trouble codes cleared	0	65535	min

Example:

Send instructions

>ATPID=04

Reception

>PID04 =0.0

3.6 ATDTC read the fault code

Example of application:

Send instructions

>ATDTC

Reception

>TCN=2, TCC=P1012P1013

3.7 ATCDI clear ECU fault code

Example:

Send instructions

>ATCDI

Reception

>\$GCAN600, ATCDI OK

3.8 ATADJ total mileage correction

Total mileage correction. Users need to enter a mileage, the mileage will be added to the "Distance traveled since codes cleared" in PID 049. Then, the total mileage read in the ATUTON is equal to the sum of the mileage of the input miles and "Distance traveled since codes cleared" in PID 049.

Example of application:

Send instructions

>ATADJ=224

Reception

>\$GCAN600, ATADJ+OK

3.9 ATVIN read VIN code

Example:

Send instructions

>ATVIN

Reception

>\$OBD-VIN=1G1JC5444R7252367

Sales and service

Shenyang Guangcheng Technology Co., Ltd.

Address: Industrial Design Center, No. 42 Chongshan
Middle Road, Huanggu District, Shenyang
City, Liaoning Province.



QQ: 2881884588

E-mail: 2881884588@qq.com

Tel: +86-24-31230060

Website: www.gcgd.net

Sales and service Tel: +86-18309815706

After - sales service telephone Number: +86-13840170070

WeChat Number:13840170070